

# Gulf Yachting Association Multihull Rating Application

**GYA Multihull Committee:**

**Tommy Clark:** [tblark@windcraft.net](mailto:tblark@windcraft.net) - **Tim Molony:** [tmolony@ochsner.org](mailto:tmolony@ochsner.org) - **Kevin Blank:** [kblank@gmail.com](mailto:kblank@gmail.com)

**Directions & Notes**

- Below is the information needed to compute a GYA multihull racing rating. Please complete all spaces/sections. If a section/space does not apply to you, mark NA or None in space. Note that all hull and rig measurements need to be in decimal feet. Here is a conversion table from inches to decimal feet. Please do not provide metric or feet and inches measurement.
  - 1"=.08 2"=.17 3"=.25 4"=.33 5"=.42 6"=.50 7"=.58 8"=.67 9"=.75 10"=.83 11"=.92
- Please fill out the application and return it digitally in PDF format to the contacts listed at the top of the application document.
- There are some spaces/sections that may require multiple answers. *For example, "Synthetic Rigging: Fore/Back/Side: Fore & Side".*
- **Cost & Payment:** The cost of a cert is \$50. Please make checks payable and mail to GYA Handicappers 2565 Palm Shores Dr, Shalimar, FL 32579. In the memo line, please write "Multihull Rating".
- The cert is good for two years.
- Ratings will be PHRF/TOT/TOD.
- Dimension references are attached below.

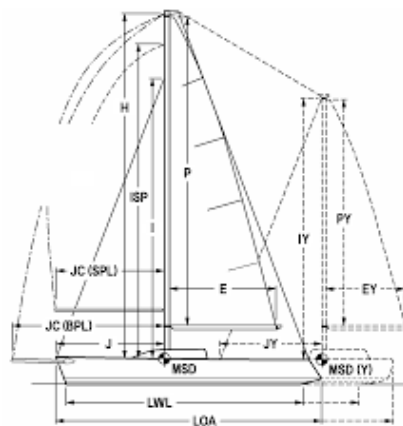
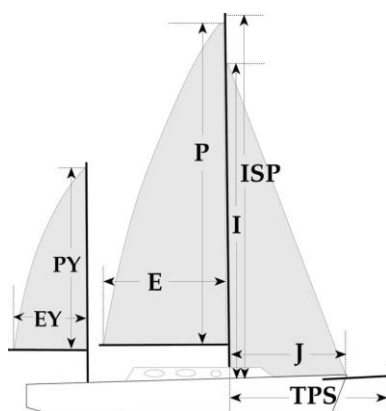

**General Information & Measurements**

Last Name, First Name: \_\_\_\_\_ Street Address: \_\_\_\_\_

City, State Zip Code: \_\_\_\_\_ Phone Number: \_\_\_\_\_

E-mail Address: \_\_\_\_\_ Yacht Club: \_\_\_\_\_

Boat Name - Sail Number: \_\_\_\_\_

Boat Model (Be specific... Corsair F-28R, not Corsair 28): \_\_\_\_\_

Manufacturer Year Built: \_\_\_\_\_ Hull ID: \_\_\_\_\_

Length Over All: \_\_\_\_\_ Length of Water Line: \_\_\_\_\_ Beam: \_\_\_\_\_

Draft Board Up: \_\_\_\_\_ Fixed Draft/Draft Board Down: \_\_\_\_\_ Displacement Dry Weight: \_\_\_\_\_

Displacement Sailing Weight: \_\_\_\_\_ Crew Weight: \_\_\_\_\_ Ballast Pounds: \_\_\_\_\_

Motor: Inboard or Outboard: \_\_\_\_\_ Prop Type: 2,3,4 Blades Fixed, Fold/Feather or Outboard: \_\_\_\_\_

Rudder Type: Spade Skeg or Transom: \_\_\_\_\_ Rig Height: Standard, Tall, Short: \_\_\_\_\_

Synthetic Standing Rigging: Fore, Back, Side: \_\_\_\_\_ Mast Material: Aluminum, Carbon, Wood: \_\_\_\_\_

Mast Details: Shape, Length/Height: \_\_\_\_\_ Rig Type: Sloop Fractional or Sloop Masthead: \_\_\_\_\_

Main Sail Mast Attachment: Bolt rope or cars/slugs: \_\_\_\_\_

Mainsail Leech: Standard, Oversized, Flat Head: \_\_\_\_\_

Keel Type: Fixed, Center Board, Dagger Board: \_\_\_\_\_

Head Stay Attachment: Hank-on, furling, UV stripe: \_\_\_\_\_

Main Sail Furling: None, Boom or Mast: \_\_\_\_\_

J: \_\_\_\_\_ I: \_\_\_\_\_ P: \_\_\_\_\_ E: \_\_\_\_\_ Jc: \_\_\_\_\_ ISP: \_\_\_\_\_

*List all sails you have for the boat: Yes/No – Sail Area – Year Made – Sail Material - % of Jib/Genoa/Screacher*

- Spin 1:
- Spin 2:
- Screacher 1:
- Screacher 2:
- Jib 1:
- Jib 2:
- Main:
- Code Zero:

**Other Equipment & Details**

Modifications to sails and sail plan since factory:

- 
- 
- 

Other PHRF/TOT/TOD ratings issued for your boat:

- 
- 

Signature: \_\_\_\_\_ Date: \_\_\_\_\_